

SYSTEMS AND COMPONENTS

**IIIIHENNIG**  
perfect machine protection.



HENNIG –  
GLOBAL, COMPETENT AND INNOVATIVE

## IIII HENNIG

perfect machine protection.

To ensure long life and efficient performance, machines must be protected against metal swarf, grinding dust, dirt and cooling agents.

Hennig has been dealing with the protection of machines since 1950. During this period several million folded bellows, telescopic steel covers, roll-away covers, apron covers, way wipers and accessories were manufactured for machine and plant manufacturers worldwide. This accumulated know-how benefits our customers in the every day production process, since their machines are optimally protected.

Hennig offers numerous new technical developments, such as telescopic steel covers designed for accelerations of up to 2.5 g and operating speeds of up to 200 m/min, depending on their geometry and sizes. Way wiper systems allow wipers to be directly replaced on the machine, decreasing down times.

# CONTENT



FLEX PROTECT/XY-MODULES

4

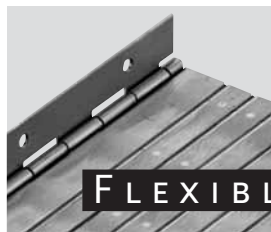

FLEXIBLE APRON COVERS

6



ROLL-UP COVERS

12



WIPER SYSTEMS

16



STABIFLEX CABLE CONDUITS

20



STABILASTIC TELESCOPIC SPRINGS

24

# FLEX PROTECT – SYSTEMS

FLEX PROTECT aluminium lamella systems protect machining centres against oil, coolants, polluted water, swarf and dust. A world-wide sales and service net ensures a fast completion of orders, fast delivery of spares and repair service near to the customers premises.

## FLEXIBLE MODULAR SYSTEM

- Design: Movable aluminium lamellas connected by polyurethane hinges.
- Reliable sealing against oil, swarf, coolants and splash due to the close contact between the lamellas and polyurethane hinges.
- Lamellas available in three widths:
  - 46 mm (single element)
  - 92 mm (double element)
  - 138 mm (triple element)
- Optimum ratio between the extended and compressed lengths.
- Extension up to 6 m per system.
- Lamella height up to 3 m.
- The polyurethane hinges serve at the same time as flexible hinges and covers between the lamellas.
- Quick and easy assembly – the end lamellas are screwed on to the adjacent machine part.
- A variety of rails and guide profiles are available for high speeds.

## GUIDES

Profile C14H

Profile C15V

Murtfeldt „S“ green

Guide roller

Bolt

PU hinge

Flex Protect lamella

- Each lamella moves in a top and bottom guide. A flat steel guide at the bottom prevents the lamella from projecting.

Bottom guide

Bottom guide rail

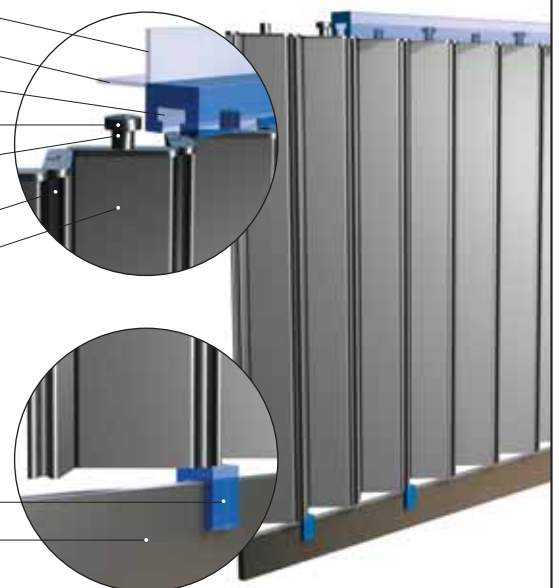

# FLEX PROTECT – SYSTEMS

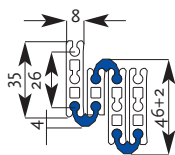

Single element 46 mm

$L_{\min} : L_{\max} \approx 1:4$

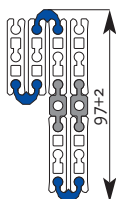

Double element 92 mm

$L_{\min} : L_{\max} \approx 1:7.5$

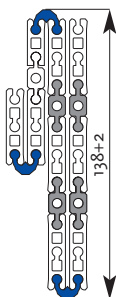

Triple element 138 mm

$L_{\min} : L_{\max} \approx 1:11.5$

## XY-MODULES

- Cover elements for the x-/y-axis movement are already integrated and depending on the requirement any choice is possible:  
X-axis: Flex Protect, plate bellows, aprons, steel covers.  
Y-axis: Plate bellows, blinds, aprons, roll-up covers.
- Developed for high dynamic loads.
- Complete assembly unit (modular system) – Components individually replaceable.



# FLEXIBLE APRON COVERS

Flexible apron covers made of steel, brass and aluminium profiles protect slideways and exposed machine parts.

The Hennig range of products consists of three groups:

Series 53 (lamella aprons) – ALUFLEX and GS 20 (hinged aprons) – Series AGS mini – AGS I – AGS II (link-type covers)

## SERIES 53 (LAMELLA APRONS)

- Lamella-type highly flexible apron covers for optimum protection against swarf and falling work pieces, especially suited for extreme working conditions.
- Sufficient protection in case of high volumes of swarf (e.g. at lathe tool posts).
- Two-layer carrier material: PUR-coated fabric at the bottom, aluminium-coated glass fibre fabric at the top (heat resistance).
- Reinforced on both sides with steel, brass or aluminium lamellas, this type of apron is a robust cover element.
- Highly resistant against oil, grease, coolants and hot swarf (contact temperature of up to + 300°C).
- Splash-proof according to IP 54.
- Small coil radius.
- Space saving.
- Easy assembly.
- Fastening is possible alternatively with angels, hinges or other fittings.

**Type 53-1**

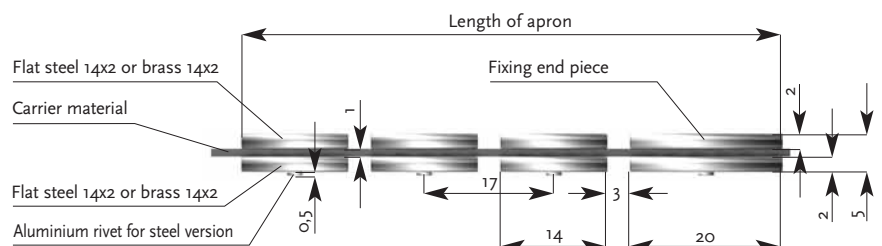

**Type 53-2**

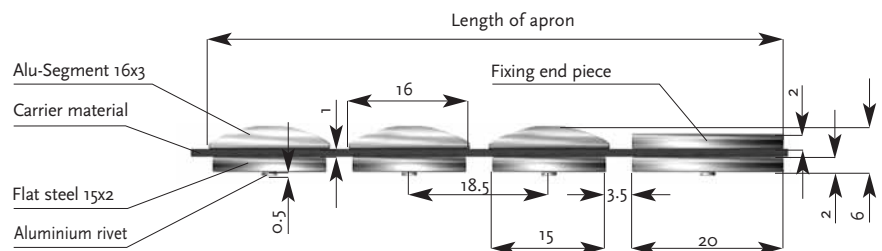



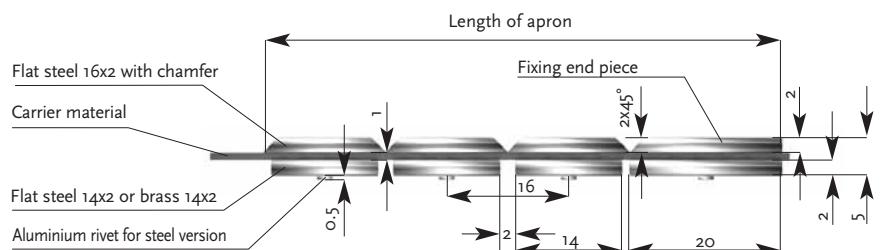









**Type 53-4**



# FLEXIBLE APRON COVERS

## SUMMARY OF TYPES STEEL APRONS

Series		53-1	53-1	53-1	53-2	53-4	53-4
Material	Top/Side of swarf	 ST 14x2	 ST 14x2	 MS 14x2	 AL 16x3	 ST 16x2	 ST 16x2
	Bottom/Side of slideway	 ST 14x2	 MS 14x2	 MS 14x2	 ST 15x2	 ST 14x2	 MS 14x2
	Carrier, or hinge, material	PAL	PAL	PAL	PAL	PAL	PAL
Technical Data	Thickness (mm)	5.5	5.5	5.5	6.5	5.5	5.5
	Return radius (min)	40	40	40	40	40	40
	Net weight N/m <sup>2</sup>	280	280	280	290	300	300
	Max. contact temperature (°C)	300	300	300	300	300	300
	Resistance to permanent contact temp. (°C)	120	120	120	120	120	120
	Coil radius ≥ R 25	25	25	25	25	25	25
Properties	Tightness (according to IP 54)	●	●	●	●	●	●
	Resistance to emulsions	◐	◐	◐	◐	◐	◐
	Suited for swarf production areas	●	●	●	◐	●	●

● Very good   ◐ Good   ◑ Suited under certain conditions   ST = Steel   MS = Brass   AL = Aluminium

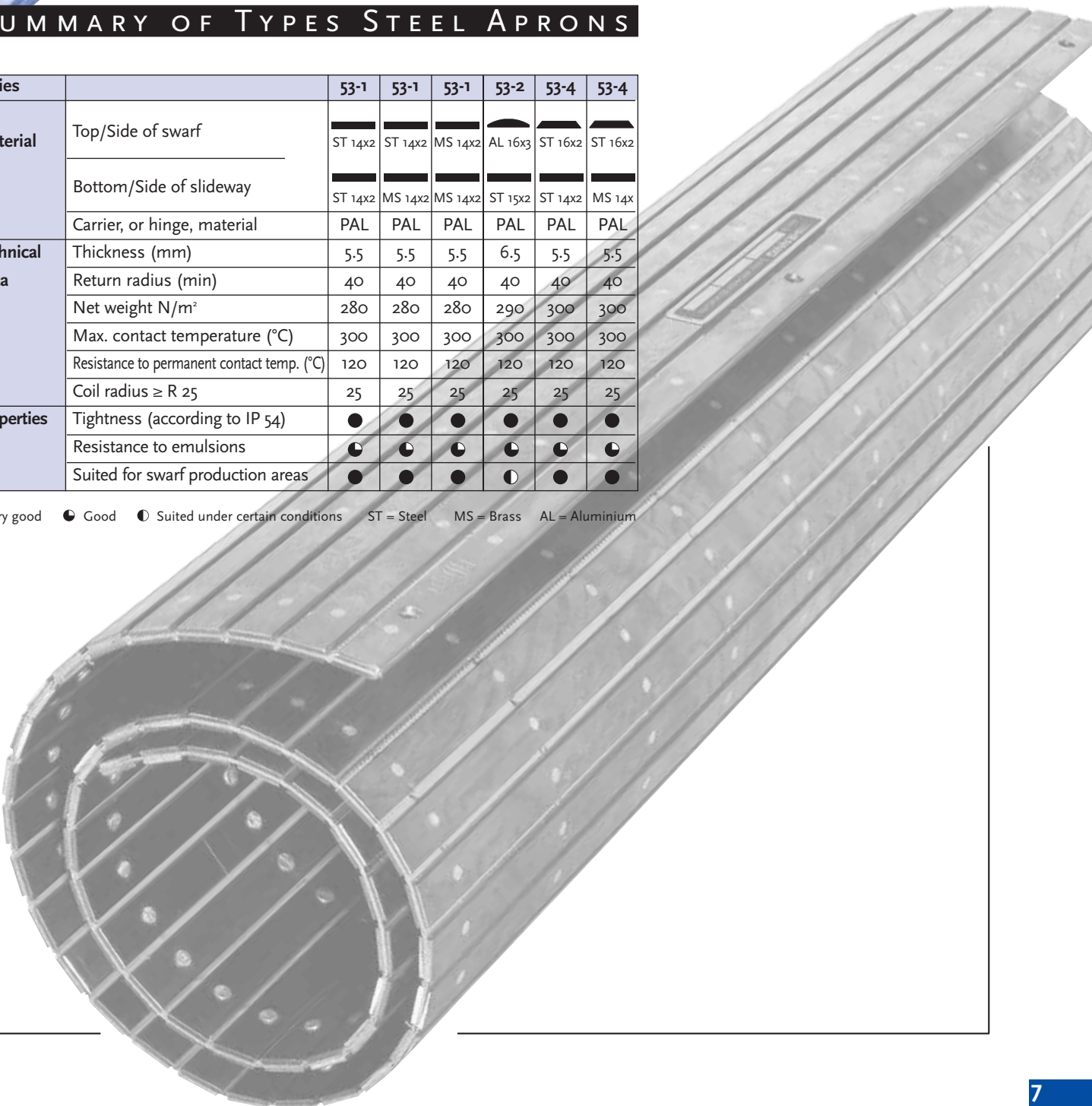

# FLEXIBLE APRON COVERS

## ALUFLEX (HINGE-TYPE APRON)

- Light, highly flexible hinge-type aluminium apron, particularly suited for the protection of machine parts which are not permanently exposed to hot swarf.
- Made of anodized aluminium precision profiles which are positively interlocked with polyurethane hinges (joints).
- The symmetric design of the aluminium profile enclosing the flexible hinges assures a high flexibility in both bending directions and space-saving stacking.
- The distance between the profiles is so small that the hinges are best protected.
- A simple but effective connection technique enables the users to easily assemble the aprons themselves from loose sections and hinges or to lengthen existing aprons.
- Splash-proof according to IP 54.

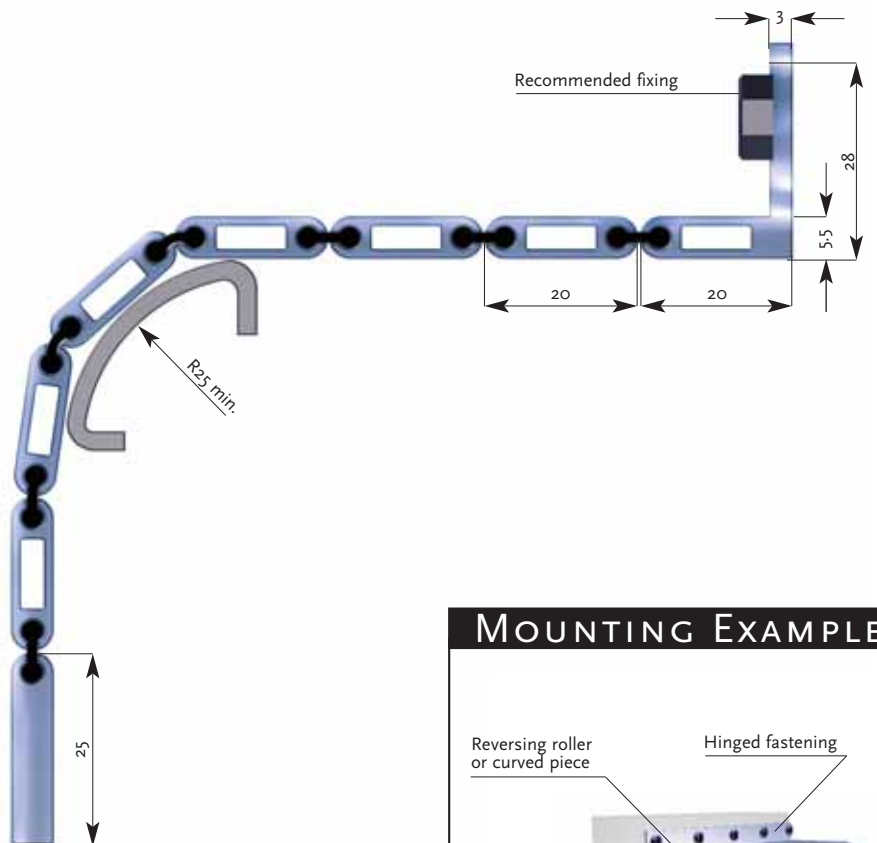

### Standard end pieces

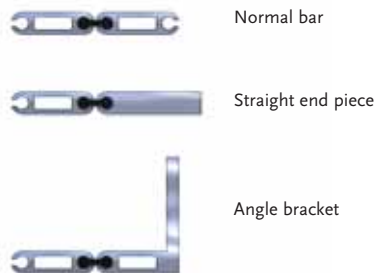

## MOUNTING EXAMPLES





# FLEXIBLE APRON COVERS

## GS 20 (HINGE-TYPE APRON)

- Light aluminium apron with locking. And so when rolled-out - completely flush between the aluminium profiles and a perfect way surface as well as - high torsional resistance and dimensional stability over the entire apron.
- The locking provides an additional optimum protection for the PU hinge.
- High torsional stiffness.

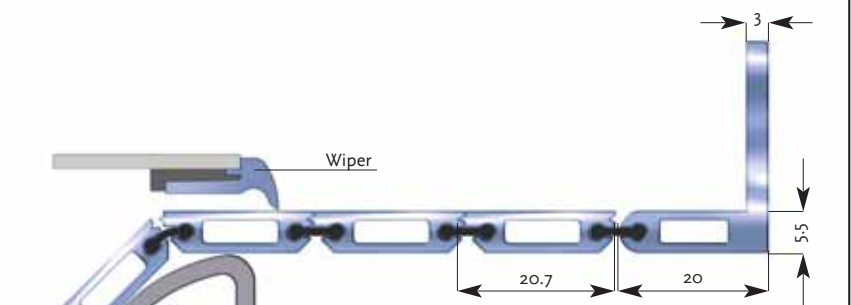
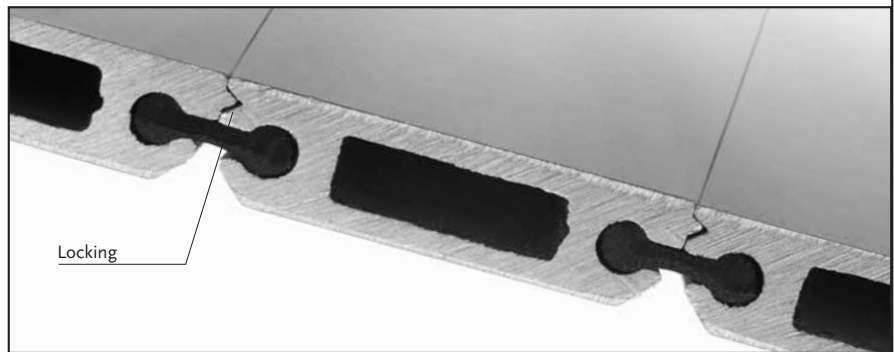

Roll-up mechanism

Reversing roller or curved piece



Reversible in two directions (only for ALUFLEX)

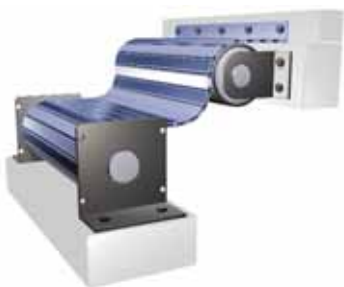

### Standard end pieces

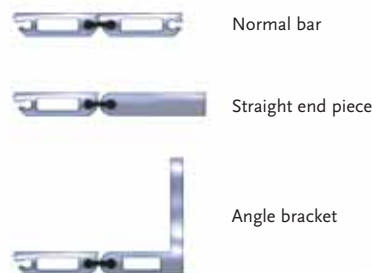

# FLEXIBLE APRON COVERS

## SERIES AGS MINI-AGS I-AGS II (LINK-TYPE APRON)

- Stable and flexible protection when space is limited.
- Made of anodized aluminium precision profiles which are perfectly interlocked.
- Special hinges prevent coarse dirt from entering and allow self-cleaning during the movement.
- Withstands high ambient temperatures.
- Resistant to corrosion by using anodized aluminium.
- High strain resistance, even in long lengths.
- Walk-on version:  
AGS I for spans of up to 750 mm.  
AGS II for spans of up to 2500 mm.
- Interchangeability of individual lamellas.
- Side guides not required.
- The AGS mini, AGS I and AGS II differ in their profile cross sections and loading capacity.
- The AGS I and AGS II are available with protruding or flat head rivets. The standard version comes with protruding rivets (2 mm on each side).
- Specially suitable for roll-up mechanisms.

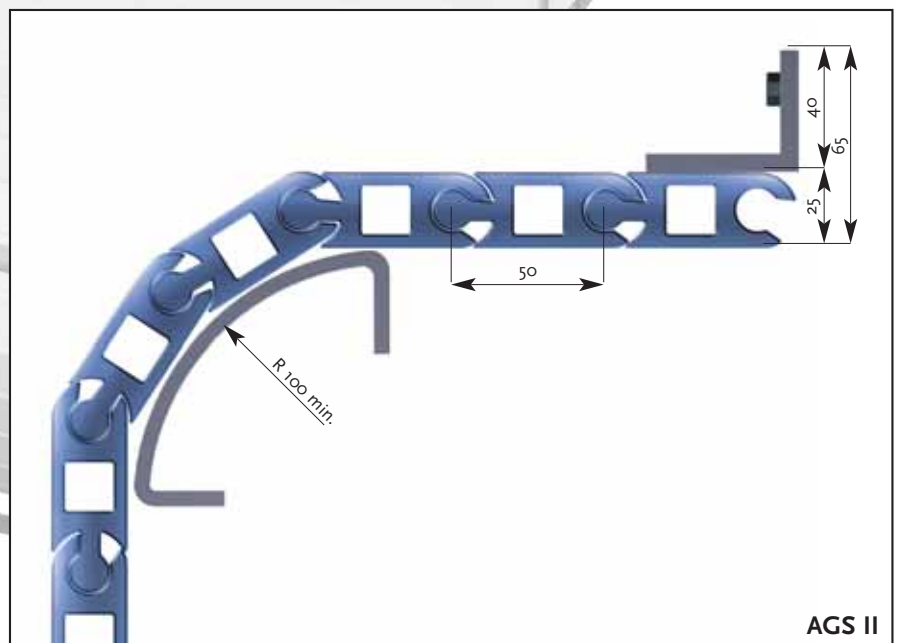
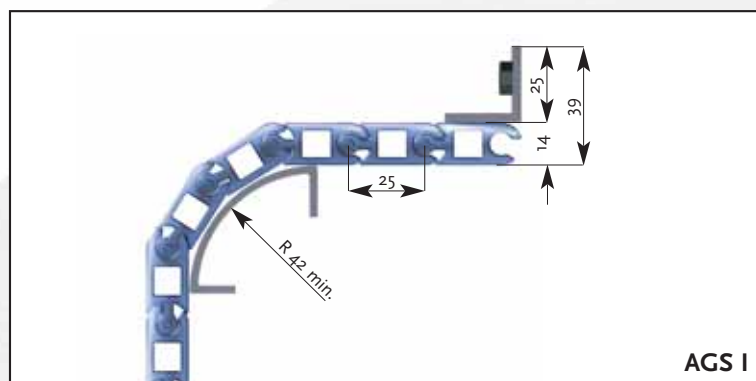
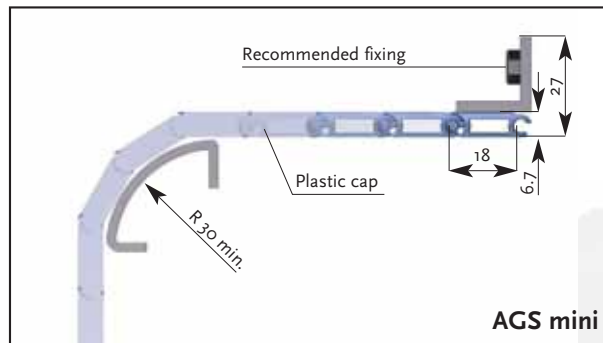

# FLEXIBLE APRON COVERS

## EXAMPLES OF GUIDES

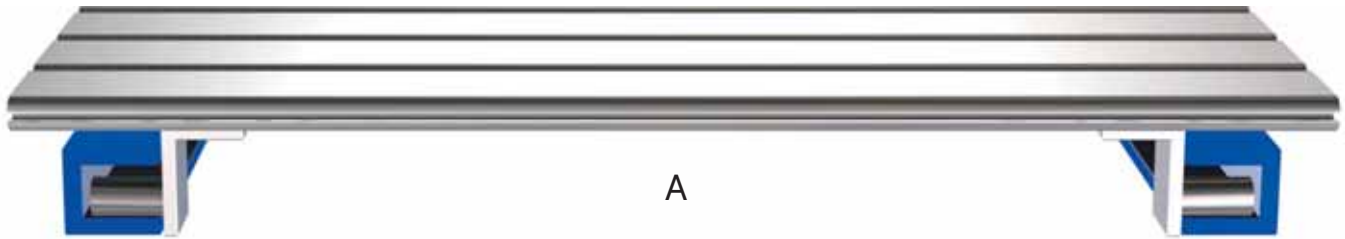

A



B

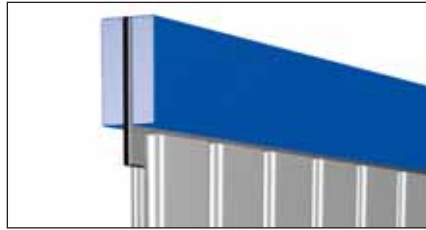



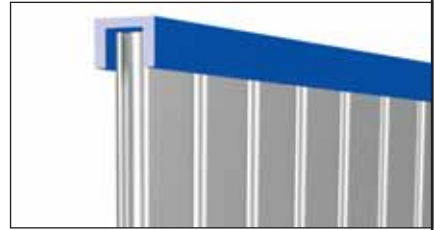

C

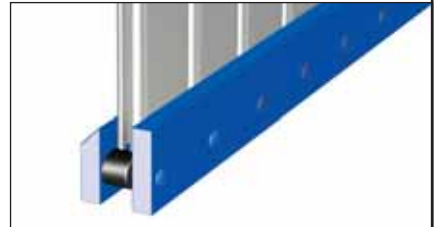
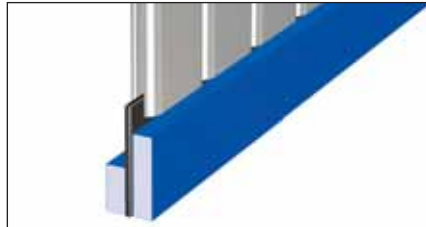
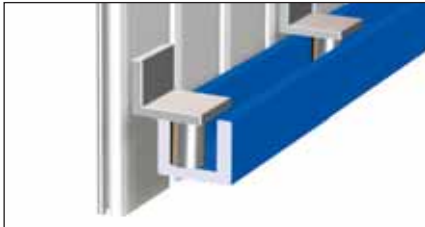

D



## SUMMARY OF TYPES ALUMINIUM APRONS

Series		Aluflex	GS 20	AGS mini	AGS I	AGS II
Type						
Material	Profile/Hinge	AL/PU	AL/PU	AL/-	AL/-	AL/-
Technical Data	Width x Thickness (mm)	20 x 5,5	20,7 x 5,5	22,4 x 6,7	34,9 x 13,8	68,3 x 25
	Return radius (min)	25	25	30	42	100
	Net weight N/m <sup>2</sup>	80	80	120	240	380
	Max. contact temperature (°C)	150	500	500	500	500
	Resistance to permanent contact temp. (°C)	120	120	200	500	500
	Coil radius ≥ R	25	25	30	42	100
Properties	Tightness (according to IP 54)	●	●	◐	◐	◐
	Resistance to emulsions	◐	◐	●	●	●
	Suited for swarf production areas	◐	●	◐	◐	◐

● Very good ◐ Good ◑ Suited under certain conditions

# ROLL-UP COVERS

## SERIES R-32, R-46, R-60

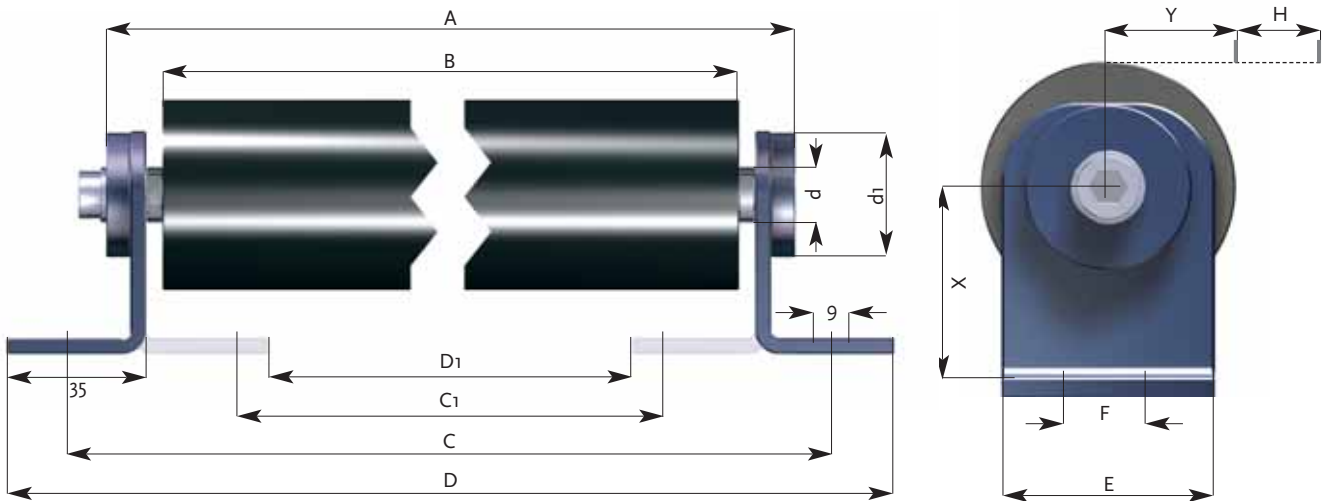

**Legend:**

- A = B + 30 mm
  - B = Band width
  - C = Hole pattern: B + 55 mm
  - C<sub>1</sub> = Hole pattern: B - 15 mm
  - D = B + 80 mm
  - D<sub>1</sub> = B - 40 mm
  - d = Diameter of shaft
  - d<sub>1</sub> = Diameter of tube
  - E = Width of lateral brackets
  - F = Hole pattern
  - H\* = Stroke
  - X = Distance between shaft centre and bracket
  - Y\* = Pre-travel
- \* To be indicated in the inquiry.



mm Type	d <sub>1</sub>	d	E	F	X
R-32	32	12	40	20	40
R-46	46	20	50	30	50
R-60	60	30	60	40	60

# ROLL-UP COVERS

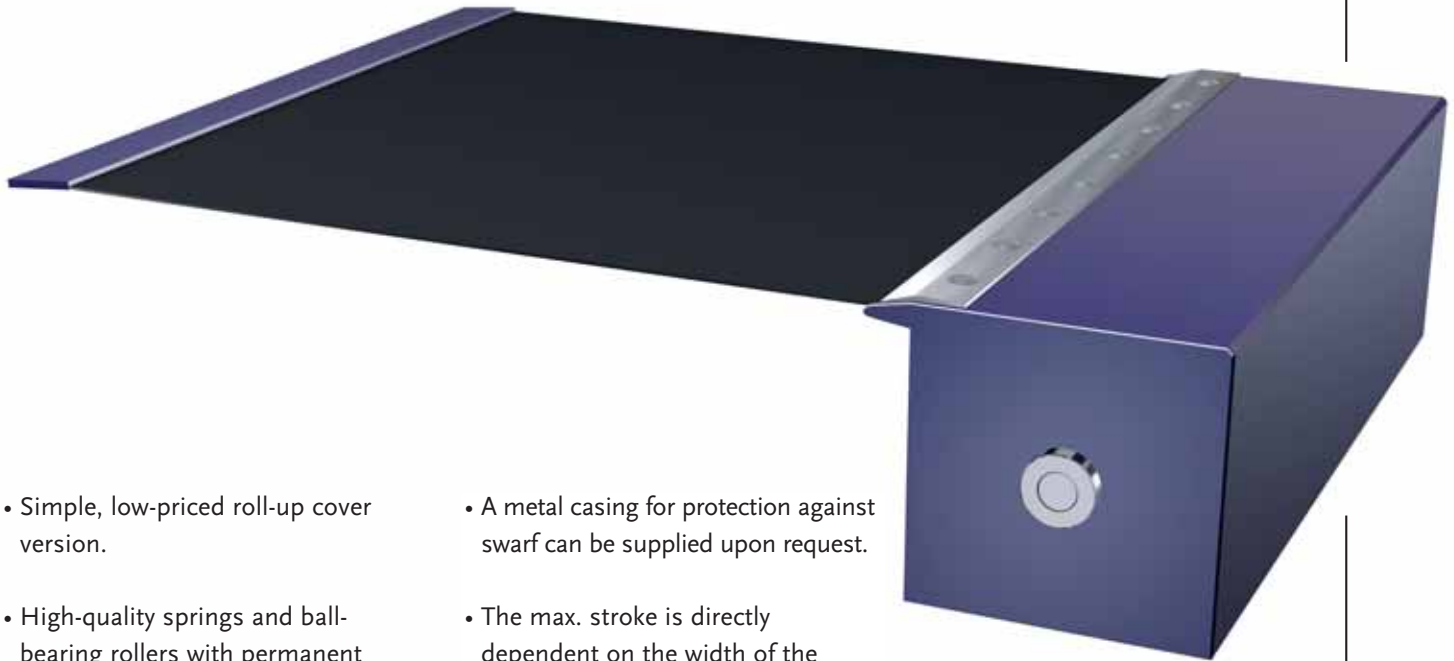

- Simple, low-priced roll-up cover version.
- High-quality springs and ball-bearing rollers with permanent lubrication ensure high operational safety.
- Drive with a special spring which is mounted in a dustproof casing.
- Max. traverse speed of 80 m/min.
- A metal casing for protection against swarf can be supplied upon request.
- The max. stroke is directly dependent on the width of the cover band.
- Mounting position: horizontal, vertical, slant, transverse
- Can be used in the open air under certain conditions.

**Roll-up covers in steel band design on request!**

**TABLE OF DIMENSIONS FOR ROLL-UP COVER SERIES R-32, R-46, R-60**

<b>R-32</b>	Band width	≥100	≥150	≥200	≥250	≥300	≥350	≥400	≥450								
	Stroke H	100	300	400	500	600	750	850	950								
	Pre-load/windings	1	1	1	1.5	1.5	2	2.5	2.5								
<b>R-46</b>	Band width		≥150	≥200	≥250	≥300	≥350	≥400	≥450	≥500	≥600	≥700	≥800	≥900	≥1000		
	Stroke H		200	400	600	750	875	1025	1150	1300	1500	1700	2000	2300	2600		
	Pre-load/windings		1.5	2	2.5	2.5	3	3.5	3.5	4	4	4.5	4.5	5	5		
<b>R-60</b>	Band width			≥200	≥250	≥300	≥350	≥400	≥450	≥500	≥600	≥700	≥800	≥900	≥1000	≥1150	≥1300
	Stroke H			350	600	900	1050	1200	1350	1550	1750	2000	2325	2650	3000	3400	4000
	Pre-load/windings			2.5	3	3	3.5	4	4	4.5	4.5	5	5.5	5.5	6	7	8

# ROLL-UP COVERS

## SERIES R-2000, R-4000, R-6000

- This system consists of three main parts:
  - Ball-bearing shaft for winding-up the cover band.
  - Completely enclosed metal casing with wipers keeping the cover band clean.
  - Spring motor which can be completely replaced if the spring breaks.
- The fastening brackets at the roll-up covers casing can be offset by 45° (see mounting options 1–6).
- The number of springs depends on the recoil force or traverse speed and will be determined at the design stage.
- No need to disassemble the cover when replacing the recoil motors (bayonet fixing).
- Width of cover band from 100 to 2500 mm. Larger widths upon request. For larger cover band widths, unsupported versions are not recommended.

Enclosed sheet metal casing with dirt wiper

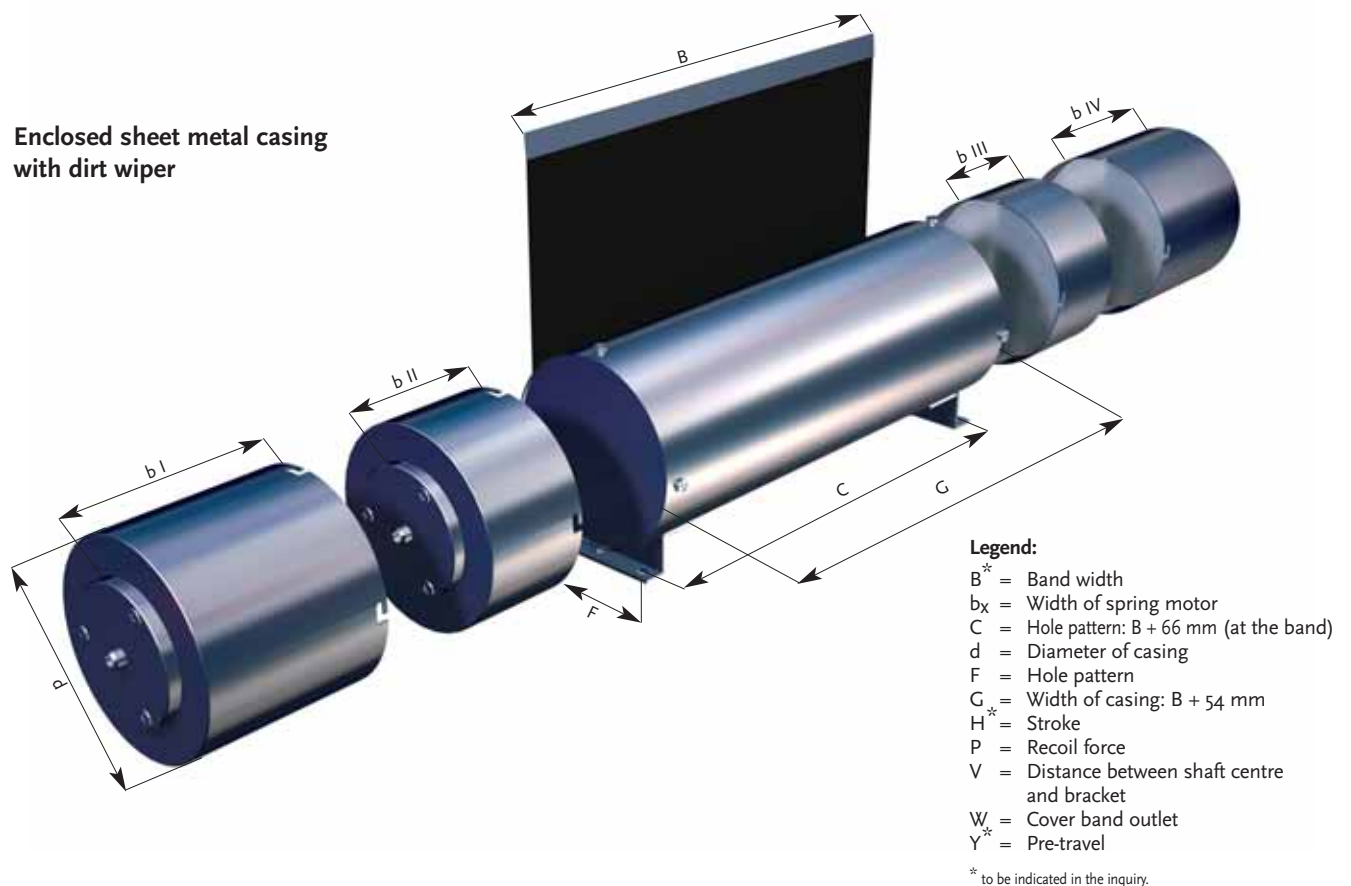

**Standard mounting possibilities** (Please indicate one of the six run-off directions in your order)

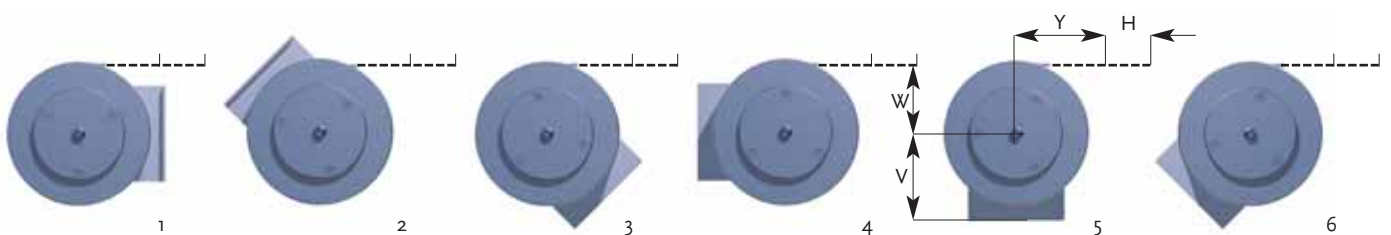

# ROLL-UP COVERS

## Cover band material for all types

- High-tensile polyamide fabrics, 0.8 to 1 mm thick.
- Coated with polyurethane on both sides.
- Highly resistant to wear.
- Tear-resistance of approx. 500 kg over a width of 5 cm (according to DIN).
- Can be used at temperatures ranging between  $-40^{\circ}\text{C}$  and  $+120^{\circ}\text{C}$ .
- Special cover bands coated with viton on one side, for contact temperatures of up to  $400^{\circ}\text{C}$ .
- Resistant against universal oils, greases and coolants, generally used in the manufacturing process.

mm Type	b <sub>I</sub>	b <sub>II</sub>	b <sub>III</sub>	b <sub>IV</sub>	d	F	V	W
R-2000	98	59	59	98	110	55	75	47
R-4000	102	63	63	102	160	108	96	68
R-6000	112	68	68	112	190	134	106	81



## Data required for orders:

- Cover band width
- Traverse of the machine
- Pre-travel
- Traverse speed of the machine
- Possible supports for the cover band
- Run-off direction

## TABLE OF DIMENSIONS FOR ROLL-UP COVER SERIES R-2000, R-4000, R-6000

Series R-2000, Max. stroke 2000 mm		
Type	Spring motor	p*
R-2000 / A	I + IV	200 N
R-2000 / B	II + IV	150 N
R-2000 / C	I + III	150 N
R-2000 / D	II + III	100 N
R-2000 / E	IV	100 N
R-2000 / F	I	100 N
R-2000 / G	III	50 N
R-2000 / H	II	50 N

Series R-4000, Max. stroke 4000 mm		
Type	Spring motor	p*
R-4000 / A	I + IV	160 N
R-4000 / B	II + IV	120 N
R-4000 / C	I + III	120 N
R-4000 / D	II + III	80 N
R-4000 / E	IV	80 N
R-4000 / F	I	80 N
R-4000 / G	III	50 N
R-4000 / H	II	50 N

Series R-6000, Max. stroke 6000 mm		
Type	Spring motor	p*
R-6000 / A	I + IV	300 N
R-6000 / B	II + IV	230 N
R-6000 / C	I + III	230 N
R-6000 / D	II + III	140 N
R-6000 / E	IV	140 N
R-6000 / F	I	140 N
R-6000 / G	III	70 N
R-6000 / H	II	70 N

\* The recoil force is subject to the wiper pre-load and only represents an average.

# WIPER SYSTEMS

The accuracy and service life of high-quality machines depends to a large extent on the correct protection and suitable cleaning of the slideways. For optimum solutions, Hennig has developed various series of way wipers in co-operation with leading machine manufacturers.

## SERIES AB

- For use in metal-cutting machines with large volumes of swarf and cooling agents.
- Well suited for the production of dimensionally stable wiper systems.
- Standard lengths can be profiled by the customer for service and repairs.
- Factory-profiled forms ensure an excellent wiping performance.
- Stainless steel support profiles ensure high mechanical stability under permanent load.
- With elastic, highly abrasion-proof polyurethane wiper lips. Permanent temperature resistance 90°C. Partly resistant to acids, leaches, gasoline.
- Easy to replace.
- The mitre joints of the wiper casing are welded.
- 90° wiper lip with a 45° chamfer moulded in one piece.
- Protected against hot swarf and mechanical damage.
- Standard lengths of 530/1000/2000 mm are available ex stock.
- Can be profiled in a nearly unlimited diversity of designs according to drawing or sketch.
- Ready to be mounted, upon request, with fixing holes.

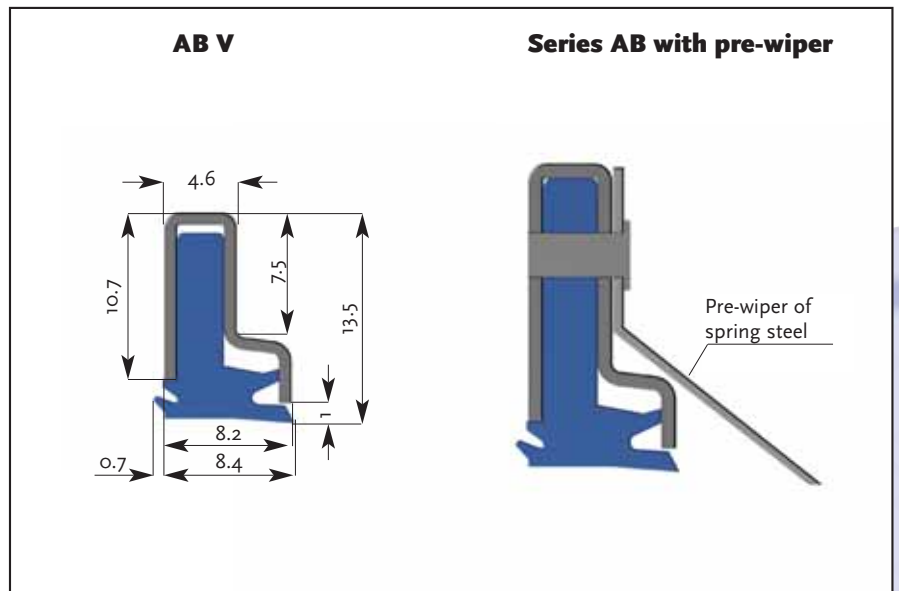
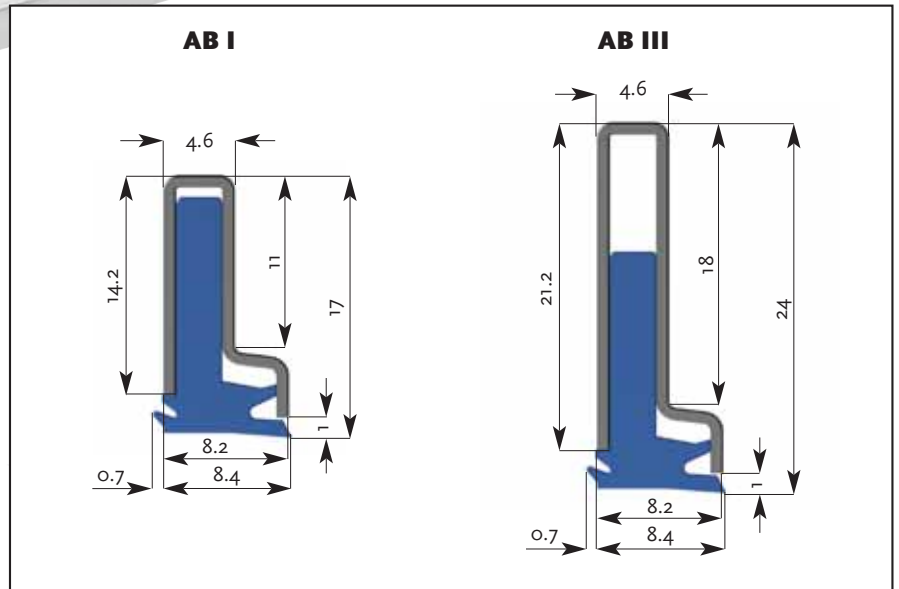



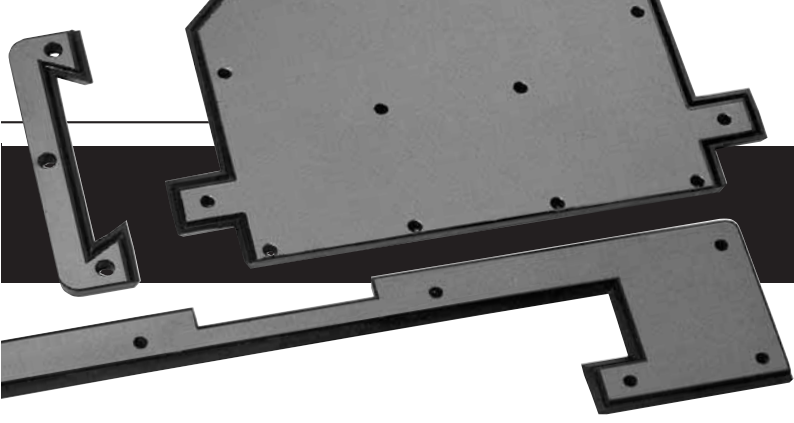

## SERIES SK

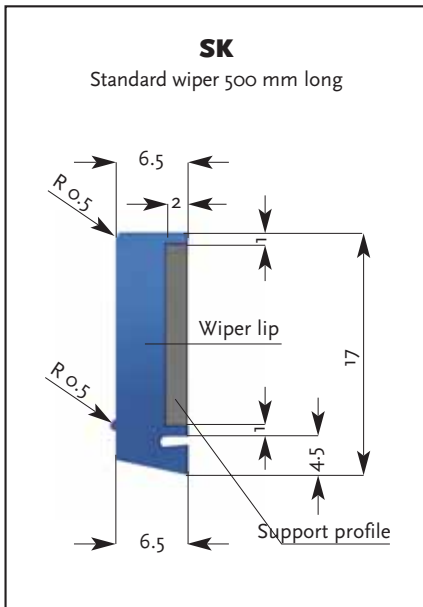

- Moulded wipers for use in series machines.
- High moulding accuracy ensures excellent wiping results.
- The wipers consist of synthetic rubber vulcanized on a steel plate.
- Support profile materials: Steel (also galvanized), high-grade steel or aluminium.
- Lip materials: NBR, silicone and NBR, silicone and Viton.
- Ready for mounting.
- Permanent temperature resistance 100°C, momentarily 135°C.
- Resistant to mineral oil and coolants.
- Resistant to micro-organisms.
- Can be manufactured in any technically feasible form.
- High dimensional accuracy.
- Good resistance to abrasion.
- Little deformation by compression.

## SERIES AL

- Particularly suitable in case of high volumes of coolants and swarf.
- Easy to cut and process, these wipers are ideal for service and repair.
- Anodized aluminium precision profile with integrated lip protection against hot swarf.
- Replaceable lip.
- The two-way wiper system prevents the penetration of swarf and coolant.
- Fastening with hexagon socket screws according to DIN 912, oval head or button head socket screw.
- The 90° connecting pieces ensure the connection of the wiper sides.

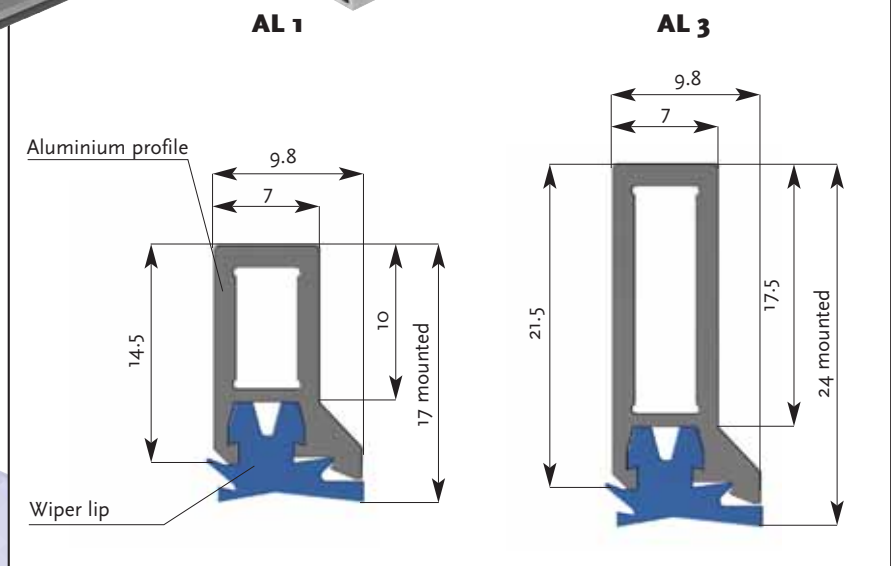
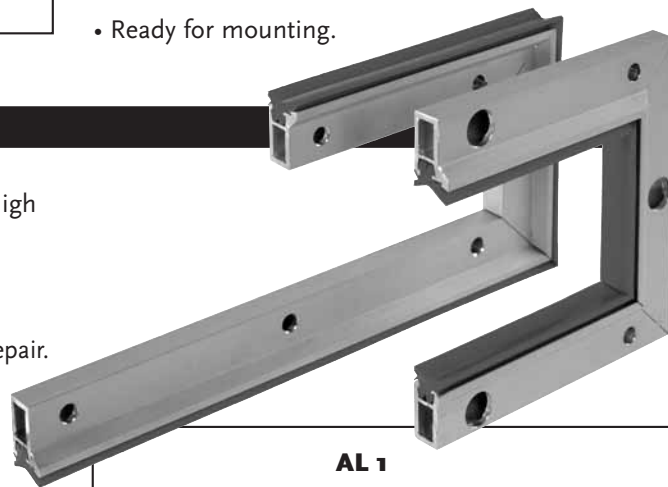

# WIPER SYSTEMS

## SERIES eN

- Mainly used on telescopic steel covers as replacement or when space is limited.
- Particularly suitable for slideways with small cross-sections.
- With a highly wear-resistant polyurethane lip vulcanized on a flat steel profile.
- The wiper lip is resistant to oil, coolants and microbes.
- The wiper types eN1 – 8x2 and eN1 – 20x2 can be profiled by the customer.
- Profiled wipers can be manufactured for all technically feasible cross-sections, ready for mounting.

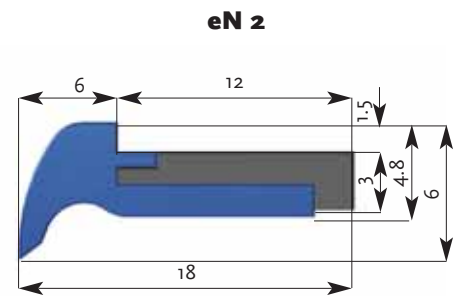
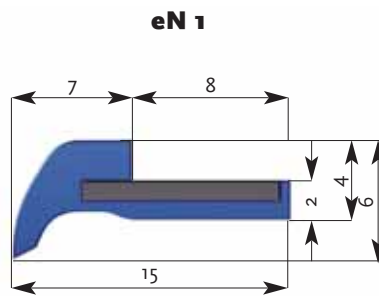

- Profiled wipers, ready for mounting, upon request, with fixing holes.
- Standard lengths of 500 mm are available ex stock.

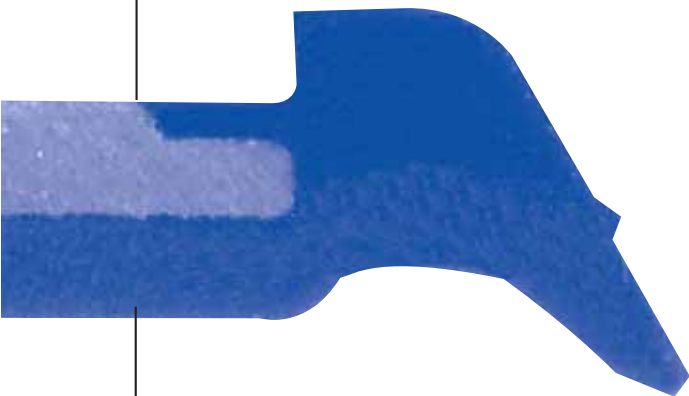
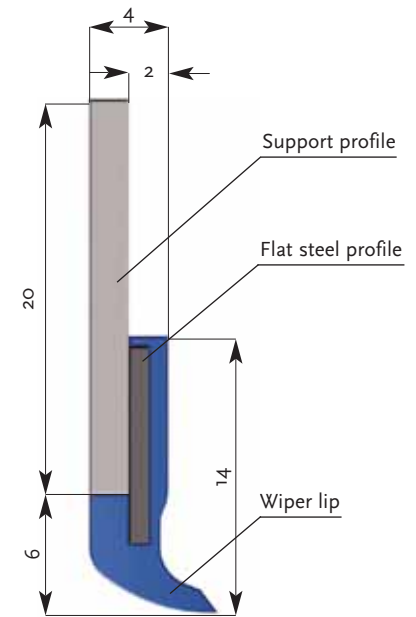
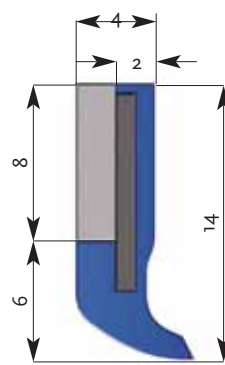

# WIPER SYSTEMS



## SERIES F (MINI)

- Compact wiper with a height of only 11.5 mm.
- Especially useful where space is limited, e.g. on extractors or slides.
- Low priced wiper based on the proven SK-series.
- The wiper lip is vulcanized on a steel profile.
- Standard lengths of 500 mm are available ex stock.

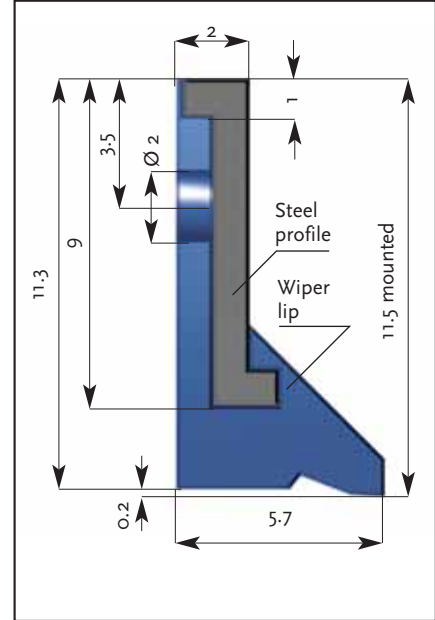

## SUMMARY OF TYPES WAY WIPERS

Features	Design											Mount. position	Recommended use	Technical Data												
	Standard length ex stock	Profiled form ex works	Minimum quantities, profiled (pieces)	Moulding cost	Standard lengths with holes	Customer-profiled	Vertical (to wiping surface)	Horizontal (to wiping surface)	Prototype/samples	Series	On pallet changers			On telescopic steel covers	Material of support profile	Material of wiper lip	Recommended pre-load (mm)	Replaceable wiper lip	Lip for 90° angles	Joint at the fastening surface	Two-way wiper lip	Resistance to permanently high temperatures	Resistance to short-term high temperatures	Resistance to abrasion	Resistance to tear propagation	Resistance to acids, alkaline solutions, petrol
Series	530 1000 2000	●	-	-	★	●	○	●	●	○	○	CrNi	PU	0.5-1	x	x	x	-	80	130	●	●	●	●	●	●
AB I / AB III / AB V																										
AL 1 AL 3	1000	-	-	-	◆	●	●	○	●	●	○	○	AL	PU	0.5-1	x	-	x	x	80	130	●	●	●	●	●
eN 1 eN 2	500					●	●	●	●	●	●	○	St	PU	0.5-1	-	-	-	-	80	130	●	●	●	●	●
eN 1-8x2 eN 1-20x2	500	●	-	-	◆	●	●	●	●	●	○	○	St	PU	0.5-1	-	-	-	-	100	130	●	●	●	●	●
F1 mini	500				◆	●	○	●	●	○	○	○	St	SK	0.5-1	-	-	x	-	100	130	●	●	●	●	●
SK	-	●	50	x	-	○	●	○	★	●	●	●	St	SK	0.5-1	-	x	x	-	100	130	●	●	●	●	●

### Legend:

● Very good   ● Good   ● Suitable under certain conditions   ○ Unsuitable   ★ Upon request   x Yes   - No   PU = Polyurethane   SK = Synthetic rubber

# STABIFLEX CABLE CONDUITS

STABIFLEX cable conduits are moving cable carriers which have proved successful in a wide range of applications in machine tools and machining centers. The main feature of this closed cable carrier is that through the fitting of a steel band to one of the four sides the flexible conduit can only bend in the one direction where the steel band is situated. In all other directions of movement the conduit remains stable.

- STABIFLEX cable conduits are resistant against all coolants and lubricants normally used in the machine tool industry. **Three qualities** are available (depending on the traverse speed):
  - **Quality N**  
Fitted with a steel band for speeds of  $v \leq 20$  m/min.
  - **Quality G**  
Featuring a steel band fixed with special glue for speeds of  $v = 20-50$  m/min.
  - **Quality K**  
Featuring a synthetic band fixed with special glue for speeds of  $v = 50$  m/min.  
If no traverse speed is indicated, we automatically choose the N quality.
- To obtain the shortest possible length, it is recommended to have the fixed connection at the mid-point of the stroke.
- When choosing the required type of STABIFLEX, an allowance of at least 10% per cable should be considered.
- Made of zinc plated sheet steel.
- To determine the bending radius (KR), multiply the outer diameter of the cables to be installed by a factor of 8 to 10. However, the minimum bending radius indicated by the cable manufacturers is the main criterion.
- Mounting flanges are welded on both ends of the cable conduit.
- In accordance with safety regulations, electrical continuity is maintained between the flanges and the metal conduit. The cables are loosely guided in the STABIFLEX and fastened at the moving and fixed end.
- A tandem version (two or three metal conduits on one steel band) can be supplied to guide various cables and hoses in separate compartments.
- To ensure long-term functioning, it is necessary to guide the STABIFLEX in support angles or in a channel the length of which should be approx. 1/2 stroke.

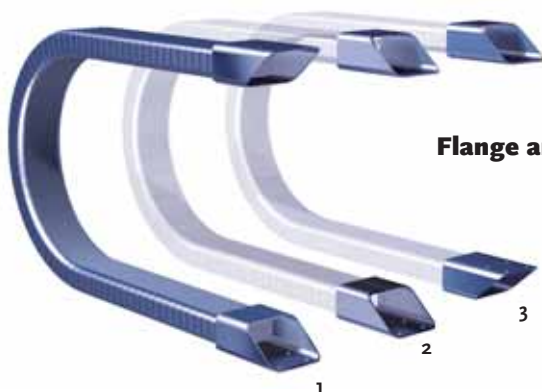

**Flange arrangements**

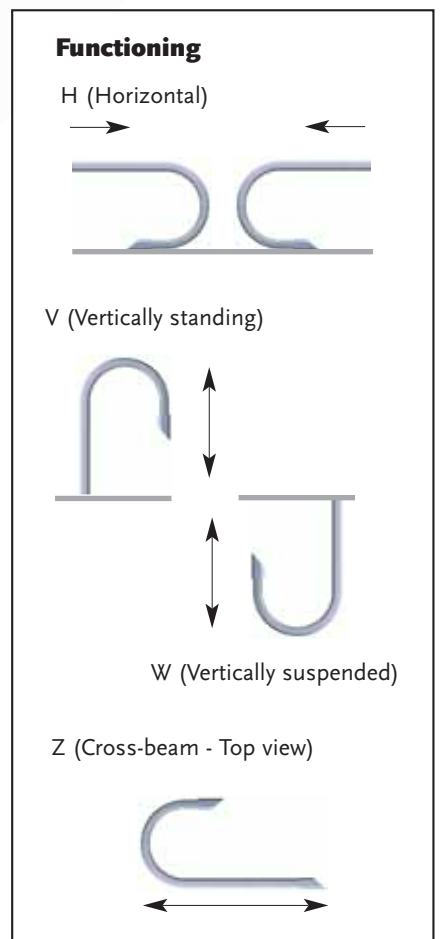

# STABIFLEX CABLE CONDUITS

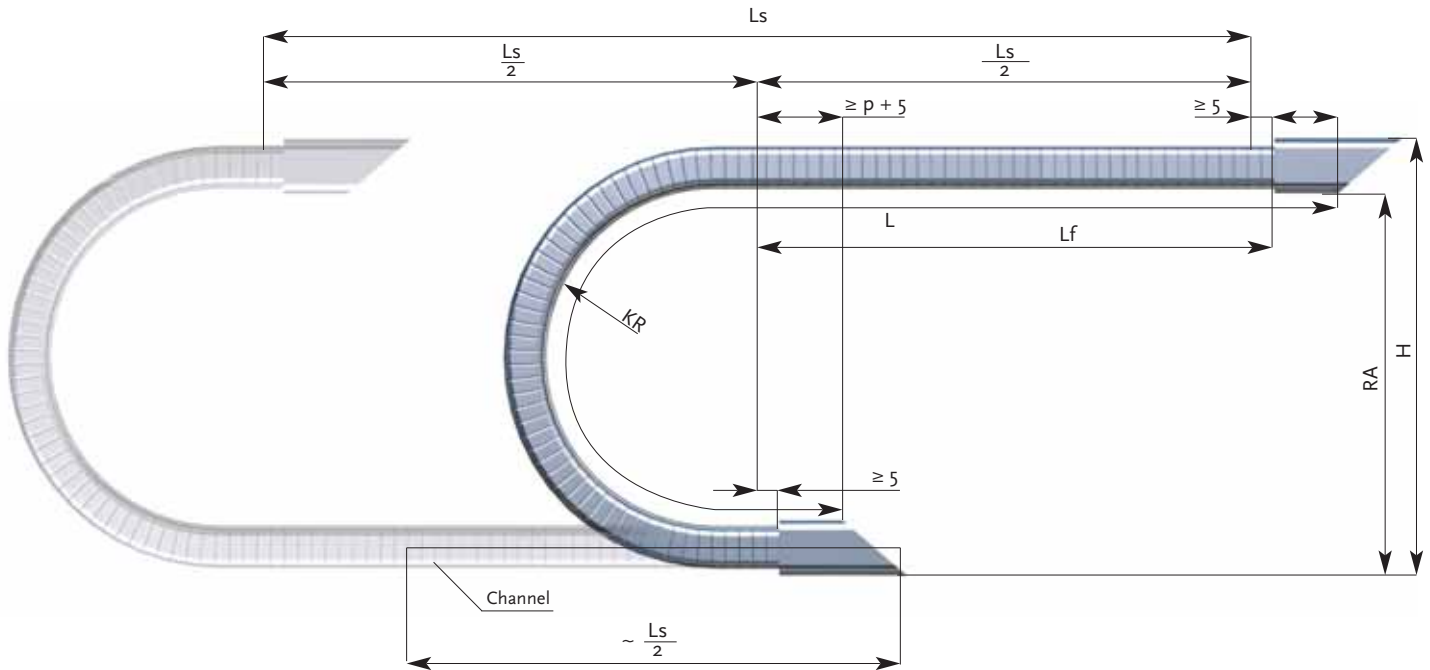

$$L = \frac{L_s}{2} + 4KR + 50 \text{ (mm) } ^*)$$

$$L = \frac{L_s}{2} + \pi KR + 2p + 10 \text{ (mm) } ^{**})$$

\*) Approximate value  
 \*\*) Formula used to calculate the precise length (rounded off to 10 mm)

### Hose cross section

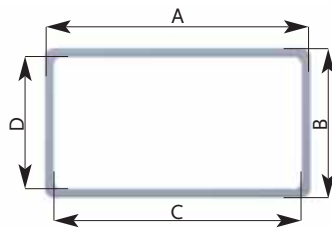

### Legend:

- A x B = STABIFLEX - outside cross-section
- C x D = STABIFLEX - inside cross-section
- Lf = Unsupported length
- L = STABIFLEX length
- Ls = Travel
- KR = Bending radius (Tolerance -20%)
- H = Mounting height
- p = Depth of conduit fitted in the flange
- RA = Minimum height of support

## DIMENSIONS AND WEIGHTS

STABIFLEX Type	A	B	C	D	p	KR <sup>+20%</sup> **)	RA (Incl. pre-load)	H	L <sub>fmax</sub>	L <sub>s</sub> Without support	L <sub>s</sub> With support	Weight Hose kg/m	Weight Flanges kg/Pair
0.0	30	20	26	16	25	55	120	144	1000	2000	4000	~ 0.6	~ 0.1
1.0	50	30	43	23	30	72 110 165	160 235 345	194 269 379	1500	3000	6000	~ 1.25	~ 0.2
1.1	50	50	45	45	50	110	240	294	2000	4000	8000	~ 1.7	~ 0.3
2.0	80	45	73	38	45	110 220 275	240 460 570	290 510 620	2000	4000	8000	~ 2.25	~ 0.5
2.1	85	60	80	55	65	165	350	415	2500	5000	10.000	~ 2.4	~ 0.6
2.2	95	50	90	45	60	130	280	335	2000	4000	8000	~ 2.9	~ 0.6
3.0	110	60	102	52	60	155 250 330	335 525 685	400 590 750	2500	5000	10.000	~ 3.6	~ 1.0
3.1	115	80	109	74	80	220	465	550	2500	5000	10.000	~ 3.8	~ 1.2
4.0	170	80	162	72	80	205	435	520	2500	5000	10.000	~ 5.6	~ 1.7
4.1	175	110	167	102	80	285	600	717	2500	5000	10.000	~ 5.8	~ 3.9

# STABIFLEX CABLE CONDUITS

## STANDARD FLANGES

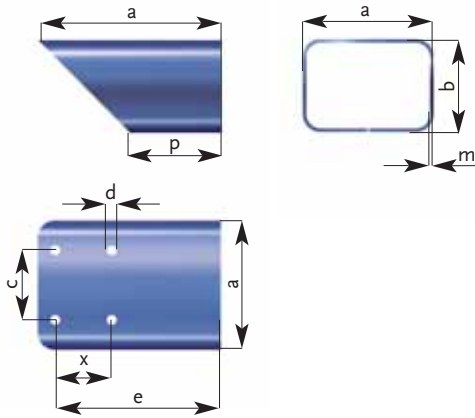

Type	a	b	c	d	e	f	p	m	x
0.0	34	24	13	6	40	50	25	1,5	–
1.0	54	34	22	7	45	60	30	1,5	–
1.1	54	54	20	7	75	100	50	1,5	–
2.0	85	50	50	7	67,5	90	45	2	–
2.1	90	65	50	7	117,5	130	65	2	40
2.2	100	55	50	7	110	120	60	2	40
3.0	115	65	70	9	90	120	60	2	–
3.1	120	85	80	9	142,5	165	80	2	40
4.0	175	85	100	9	120	160	80	2	–
4.1	182	117	140	9	157,5	195	80	3	40

## FACE TYPE FLANGES - TYPE A

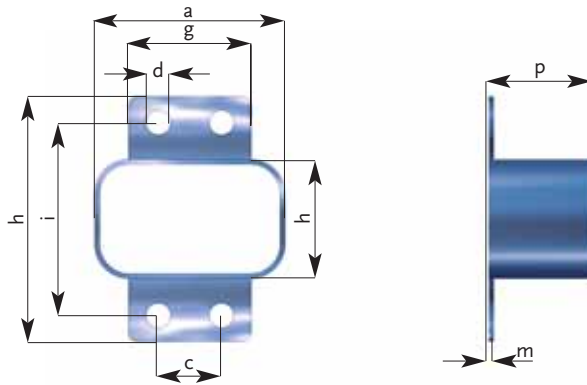

Type	a	b	c	d	g	h	i	p	m
1.0	54	34	18	7	35	70	55	30	1,5
2.0	85	50	45	7	65	85	70	45	2
3.0	115	65	60	9	80	110	90	60	2
4.0	175	85	95	9	120	130	110	80	2

# STABIFLEX CABLE CONDUITS

## FACE TYPE FLANGES - TYPE B

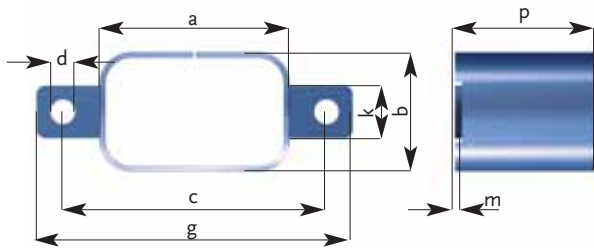

Type	a	b	c	d	g	k	p	m
1.0	54	34	75	7	90	15	30	1.5
2.0	85	50	105	7	120	30	45	2
3.0	115	65	140	9	160	35	60	2
4.0	175	85	200	9	220	40	80	2

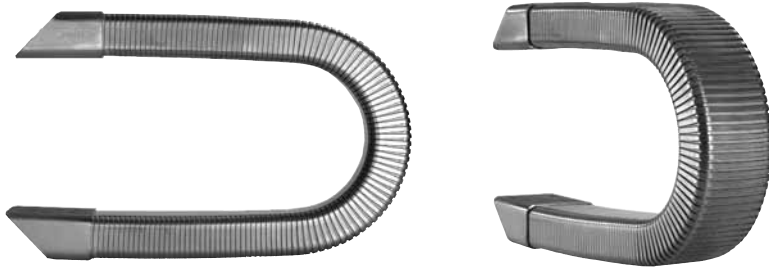

## FACE TYPE FLANGES - TYPE C

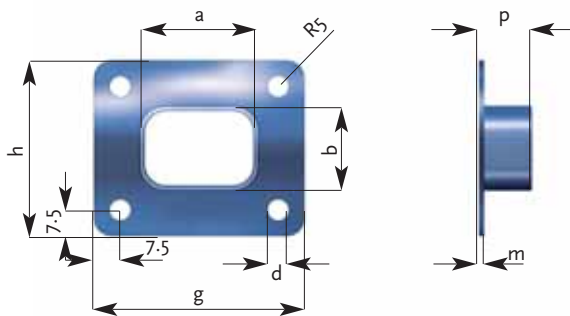

Type	a	b	d	g	h	p	m
0.0	34	24	6	60	50	25	1.5
1.1	54	54	7	85	85	50	1.5
2.1	90	65	7	120	95	65	2
2.2	100	55	7	130	85	60	2
3.1	120	85	9	150	115	80	2
4.1	182	117	9	210	145	80	3

# STABILASTIC TELESCOPIC SPRINGS



STABILASTIC telescopic springs ensure the protection of ballscrews, threads and guide columns against dirt, swarf and mechanical damage.

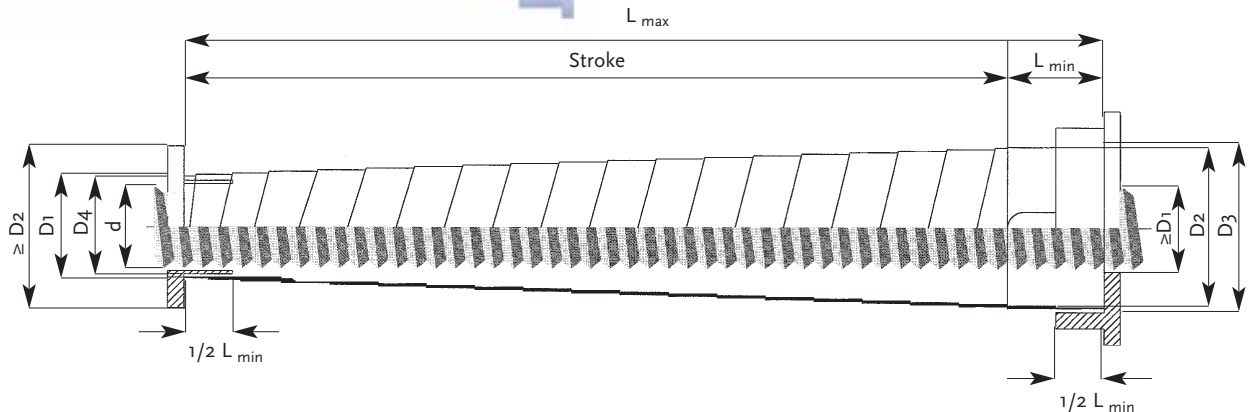

## PRODUCT INFORMATION

- Telescopic springs made of hardened high-grade spring steel ensure an excellent protection against dirt, swarf and mechanical damage even when fully extended.
- Minimum overlap (of the individual windings) of 40%.
- A special manufacturing method and optimal resilience ensure an easy compression and extension. Horizontal springs have a minimal sag and vertically used springs only a slight lateral deviation.
- Winding-on types are available up to the size 54/1120/120.
- Easy assembly by pushing the springs over the machine parts.

### Assembly and maintenance:

Regular flanges and collars are sufficient for the location of the spring ends. However, these items are not supplied by Hennig. The minimum diameter of the take-up collar D3 must not be smaller than indicated. If the inside diameter of the take-up collar D3 is too small, or if the outside diameter of the centering flange D4 is too large, the spring will have a tendency to jam. For horizontal applications, we recommend to install the Stabilastic springs with the large diameter nearest to the swarf accumulation area and for vertical applications, with the large diameter at the top. The maximum sag in horizontal installations will be approx. 2 – 3% of the maximum mounting length.

### Legend:

- d = Max. diameter of the machine part to be protected
- D1<sub>min</sub> = Inside diameter
- D2<sub>max</sub> = Outside diameter
- D3 = Inside diameter of the collar (D2 + 2mm)
- D4 = Outside diameter of the centering flange (D1 - 1mm)
- L<sub>max</sub> = Max. extended length
- L<sub>min</sub> = Minimum extended length
- Hub = Max. travel

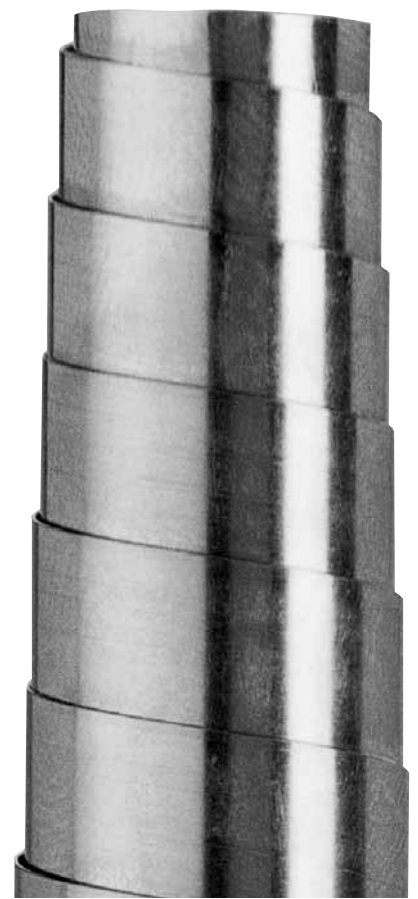



# STABILASTIC TELESCOPIC SPRINGS

## RANGE OF TELESCOPIC SPRINGS

Type			Part number	d	D2	Vertical Application		Horizontal Application		kg/piece
D1	L <sub>max</sub> (V)	L <sub>min</sub>				L <sub>max</sub>	Stroke	L <sub>max</sub>	Stroke	
18	250	32	307.0180 10	15	36	250	218	250	218	0.13
20	100	20	307.0200 10	17	31	100	80	60	40	0.06
20	150	20	307.0200 20	17	34	150	130	110	90	0.07
20	200	20	307.0200 30	17	36	200	180	160	140	0.09
20	250	20	307.0200 40	17	40	250	230	210	190	0.12
20	250	40	307.0200 50	17	38	250	210	250	210	0.18
20	300	30	307.0200 60	17	39	300	270	240	210	0.17
20	350	30	307.0200 70	17	42	350	320	290	260	0.20
20	400	30	307.0200 80	17	45	400	370	340	310	0.24
23	250	40	307.0230 10	20	41	250	210	250	210	0.18
23	400	40	307.0230 20	20	45	400	360	400	360	0.31
25	100	20	307.0250 10	22	35	100	80	60	40	0.06
25	300	30	307.0250 20	22	43	300	270	240	210	0.18
25	350	30	307.0250 30	22	46	350	320	290	260	0.22
25	450	40	307.0250 40	22	48	450	410	370	330	0.30
25	500	40	307.0250 50	22	51	500	460	420	380	0.35
26	250	50	307.0260 10	23	43	250	200	250	200	0.24
26	400	50	307.0260 20	23	47	400	350	400	350	0.33
30	150	30	307.0300 10	27	39	150	120	90	60	0.10
30	250	30	307.0300 20	27	45	250	220	190	160	0.18
30	315	50	307.0300 30	27	57	315	265	315	265	0.56
30	350	30	307.0300 40	27	51	350	320	290	260	0.27
30	550	40	307.0300 50	27	58	550	510	470	430	0.48
30	630	65	307.0300 60	27	58	630	565	630	565	0.74
30	650	50	307.0300 70	27	55	650	600	550	500	0.52
30	900	90	307.0300 80	27	63	900	810	900	810	1.33
34	315	50	307.0340 10	30	60	315	265	315	265	0.59
34	630	65	307.0340 20	30	65	630	565	630	565	0.94
34	900	90	307.0340 30	30	65	900	810	900	810	1.37
38	400	60	307.0380 10	35	64	400	340	400	340	0.73
38	800	85	307.0380 20	35	71	800	715	800	715	1.48
38	1120	120	307.0380 30	35	77	1120	1000	1120	1000	2.61
38	1400	120	307.0380 40	35	80	1400	1280	1400	1280	2.85
40	150	30	307.0400 10	37	52	150	120	90	60	0.18
40	250	30	307.0400 20	37	57	250	220	190	160	0.27
40	350	30	307.0400 30	37	64	350	320	290	260	0.41
40	450	40	307.0400 40	37	65	450	410	370	330	0.54
40	450	50	307.0400 50	37	60	450	400	350	300	0.51
40	550	40	307.0400 60	37	71	550	510	470	430	0.71
40	550	50	307.0400 70	37	65	550	500	450	400	0.67
40	650	50	307.0400 80	37	69	650	600	550	500	0.81
40	750	50	307.0400 90	37	74	750	700	650	600	1.00
40	750	60	307.0401 00	37	68	750	690	630	570	0.93
40	900	60	307.0401 10	37	74	900	840	780	720	1.19
40	1000	100	307.0401 20	37	66	1000	900	800	700	1.36
40	1100	75	307.0401 30	37	78	1100	1025	950	875	1.66
40	1500	100	307.0401 40	37	78	1500	1400	1300	1200	2.21
40	1800	100	307.0401 50	37	82	1800	1700	1600	1500	2.53
43	400	60	307.0430 10	40	72	400	340	400	340	0.95
43	800	85	307.0430 20	40	81	800	715	800	715	2.04
43	1120	120	307.0430 30	40	83	1120	1000	1120	1000	2.85
43	1400	120	307.0430 40	40	84	1400	1280	1400	1280	3.12
48	400	65	307.0480 10	45	78	400	335	400	335	1.26
48	800	85	307.0480 20	45	85	800	715	800	715	2.05

On request - minimum purchasing quantity 10 pcs.

# STABILASTIC TELESCOPIC SPRINGS

## RANGE OF TELESCOPIC SPRINGS

Type			Part number	d	D2	Vertical Application		Horizontal Application		kg/piece
D1	L <sub>max</sub> (V)	L <sub>min</sub>				L <sub>max</sub>	Stroke	L <sub>max</sub>	Stroke	
48	1120	120	307.0480 30	45	91	1120	1000	1120	1000	3.46
48	1400	130	307.0480 40	45	96	1400	1270	1400	1270	4.26
48	1800	130	307.0480 50	45	106	1800	1670	1800	1670	5.50
50	150	30	307.0500 10	47	63	150	120	90	60	0.25
50	250	30	307.0500 20	47	68	250	220	190	160	0.35
50	250	50	307.0500 30	47	62	250	200	150	100	0.35
50	350	50	307.0500 40	47	66	350	300	250	200	0.48
50	450	50	307.0500 50	47	70	450	400	350	300	0.62
50	550	50	307.0500 60	47	75	550	500	450	400	0.80
50	650	60	307.0500 70	47	74	650	590	530	470	0.92
50	750	60	307.0500 80	47	78	750	690	630	570	1.10
50	750	75	307.0500 90	47	78	750	675	600	525	1.38
50	900	75	307.0501 00	47	84	900	825	750	675	1.75
50	1100	75	307.0501 10	47	92	1100	1025	950	875	2.30
50	1300	100	307.0501 20	47	81	1300	1200	1100	1000	2.00
50	1500	100	307.0501 30	47	87	1500	1400	1300	1200	2.50
50	1800	100	307.0501 40	47	95	1800	1700	1600	1500	3.22
50	2100	120	307.0501 50	47	100	2100	1980	1860	1740	4.03
50	2300	120	307.0501 60	47	105	2300	2180	2060	1940	4.58
54	400	65	307.0540 10	50	84	400	335	400	335	1.38
54	800	85	307.0540 20	50	94	800	715	800	715	2.53
54	1120	120	307.0540 30	50	93	1120	1000	1120	1000	3.20
54	1400	130	307.0540 40	50	102	1400	1270	1400	1270	4.61
54	1800	140	307.0540 50	50	116	1800	1660	1800	1660	7.58
55	250	30	307.0550 10	51	76	250	220	190	160	0.46
55	550	60	307.0550 20	51	79	550	490	430	370	1.03
55	900	75	307.0550 30	51	92	900	825	750	675	2.09
55	1500	100	307.0550 40	51	96	1500	1400	1300	1200	3.18
60	150	30	307.0600 10	54	74	150	120	90	60	0.32
60	250	30	307.0600 20	54	82	250	220	190	160	0.53
60	350	50	307.0600 30	54	80	350	300	250	200	0.74
60	450	50	307.0600 40	54	84	450	400	350	300	0.92
60	550	60	307.0600 50	54	85	550	490	430	370	1.16
60	750	60	307.0600 60	54	89	750	690	630	570	1.52
60	900	75	307.0600 70	54	95	900	825	750	675	2.09
60	1300	100	307.0600 80	54	96	1300	1200	1100	1000	2.88
60	1900	120	307.0600 90	54	110	1900	1780	1660	1540	4.83
60	2100	120	307.0601 00	54	115	2100	1980	1860	1740	5.47
60	2300	120	307.0601 10	54	122	2300	2180	2060	1940	6.42
61	630	90	307.0610 10	55	98	630	540	630	540	2.55
61	900	100	307.0610 20	55	104	900	800	900	800	3.56
61	1250	120	307.0610 30	55	116	1250	1130	1250	1130	5.65
61	1800	140	307.0610 40	55	132	1800	1660	1800	1660	9.46
65	250	30	307.0650 10	59	86	250	220	190	160	0.53
65	250	50	307.0650 20	59	79	250	200	150	100	0.54
65	350	50	307.0650 30	59	85	350	300	250	200	0.80
65	550	60	307.0650 40	59	88	550	490	430	370	1.19
65	1300	100	307.0650 50	59	103	1300	1200	1100	1000	3.28
65	1800	100	307.0650 60	59	118	1800	1700	1600	1500	4.98
65	1900	120	307.0650 70	59	115	1900	1780	1660	1540	5.12
65	2100	120	307.0650 80	59	120	2100	1980	1860	1740	5.79
65	2300	120	307.0650 90	59	125	2300	2180	2060	1940	6.48
69	630	100	307.0690 10	60	106	630	530	630	530	3.18
69	900	100	307.0690 20	60	117	900	800	900	800	4.81

On request - minimum purchasing quantity 10 pcs.

# STABILASTIC TELESCOPIC SPRINGS

## RANGE OF TELESCOPIC SPRINGS

Type			Part number	d	D2	Vertical Application		Horizontal Application		kg/piece
D1	L <sub>max</sub> (V)	L <sub>min</sub>				L <sub>max</sub>	Stroke	L <sub>max</sub>	Stroke	
69	1250	120	307.0690 30	60	128	1250	1130	1250	1130	7.08
70	250	30	307.0700 10	61	95	250	220	190	160	0.70
70	350	50	307.0700 20	61	92	350	300	250	200	0.97
70	550	60	307.0700 30	61	98	550	490	430	370	1.53
70	650	60	307.0700 40	61	104	650	590	530	470	1.93
70	750	60	307.0700 50	61	110	750	690	630	570	2.35
70	900	75	307.0700 60	61	110	900	825	750	675	2.85
70	1100	75	307.0700 70	61	118	1100	1025	950	875	3.57
70	1300	100	307.0700 80	61	113	1300	1200	1100	1000	4.16
75	450	50	307.0750 10	66	104	450	400	350	300	1.41
75	550	60	307.0750 20	66	104	550	490	430	370	1.69
75	650	60	307.0750 30	66	110	650	590	530	470	2.11
75	750	60	307.0750 40	66	115	750	690	630	570	2.48
75	900	75	307.0750 50	66	115	900	825	750	675	3.01
75	1700	100	307.0750 60	66	133	1700	1600	1500	1400	6.37
75	1800	120	307.0750 70	66	130	1800	1680	1560	1440	6.67
78	900	110	307.0780 10	70	123	900	790	900	790	5.05
78	1250	120	307.0780 20	70	135	1250	1130	1250	1130	7.39
78	1800	150	307.0780 30	70	144	1800	1650	1800	1650	11.15
80	650	75	307.0800 10	70	108	650	575	500	425	2.09
80	750	75	307.0800 20	70	112	750	675	600	525	2.43
80	1300	100	307.0800 30	70	125	1300	1200	1100	1000	4.87
80	1800	120	307.0800 40	70	135	1800	1680	1560	1440	7.00
88	900	110	307.0880 10	80	131	900	790	900	790	5.26
88	1250	140	307.0880 20	80	140	1250	1110	1250	1110	8.42
88	1800	150	307.0880 30	80	157	1800	1650	1800	1650	13.16
90	250	50	307.0900 10	80	116	250	200	150	100	1.52
90	350	50	307.0900 20	80	122	350	300	250	200	1.92
90	750	100	307.0900 30	80	118	750	650	550	450	3.14
90	1100	100	307.0900 40	80	132	1100	1000	900	800	5.03
98	1250	140	307.0980 10	85	156	1250	1110	1250	1110	10.70
100	800	100	307.1000 10	90	130	800	700	600	500	3.72
108	900	140	307.1080 10	95	147	900	760	900	760	6.00
108	1250	150	307.1080 20	95	161	1250	1100	1250	1100	11.30
110	600	75	307.1100 10	100	144	600	525	450	375	3.55
110	2200	180	307.1100 20	100	178	2200	2020	1840	1660	18.89
120	2600	200	307.1200 10	110	184	2600	2400	2200	2000	20.19
123	900	140	307.1230 10	100	169	900	760	900	760	9.76

On request - minimum purchasing quantity 10 pcs.

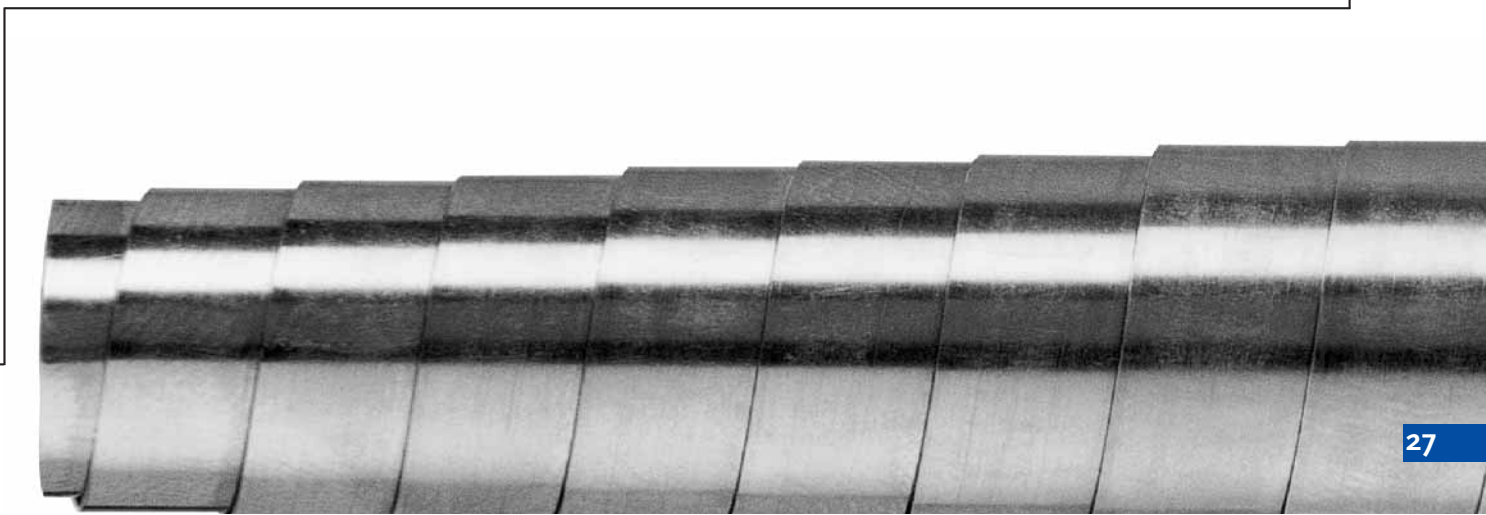

Hennig GmbH

Postfach/PO Box 1343  
85543 Kirchheim  
Germany  
Tel./Phone +49 89 960 96-0  
Fax +49 89 960 96-120

Überrheinerstr. 5  
85551 Kirchheim  
Germany  
info@hennig-gmbh.de  
www.hennig-gmbh.de

All members of  
the Hennig group are  
DIN ISO 9001:2000 certified.

[www.hennigworldwide.com](http://www.hennigworldwide.com)